

METERED SERVICE WIRING SCHEMATIC DIAGRAM

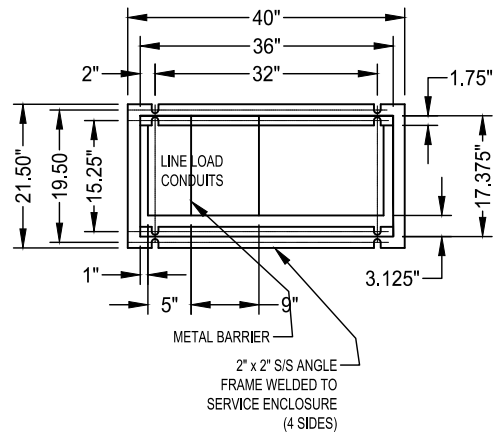

BASE PLATE DETAIL

- EXTERIOR SHALL BE 14 GAUGE #304D STAINLESS STEEL, INTERIOR SHALL BE 14 GAUGE STEEL, PAINTED WHITE. ENCLOSURE SHALL BE ELECTRICALLY WELDED AND REINFORCED WHERE REQUIRED.
- CONSTRUCTION SHALL BE NEMA 3R AND 12, RAIN TIGHT AND DUST TIGHT.
- ALL NUTS, BOLTS, SCREWS AND HINGES SHALL BE STAINLESS STEEL.
- NUTS, BOLTS, AND SCREWS SHALL NOT BE USED ON THE OUTSIDE OF THE SERVICE ENCLOSURE.
- PHENOLIC NAMEPLATES SHALL BE USED TO IDENTIFY ALL OPERATION CONTROLS.
- CONTROL WIRING SHALL BE MARKED AT BOTH ENDS BY PERMANENT WIRE MARKERS.
- A PLASTIC COVERED WIRING DIAGRAM SHALL BE ATTACHED TO THE INSIDE OF THE FRONT DOOR.
- SERVICE ENCLOSURE SHALL BE FACTORY WIRED AND CONFORM TO REQUIRED NEMA STANDARDS.
- SERVICE ENCLOSURE SHALL BE U.L. LISTED AS INDUSTRIAL CONTROL PANELS U.L. 508 FILE NO. E62062.
- WIRING BETWEEN CIRCUIT BREAKER AND CONTACTOR SHALL BE #6 THWN OR THHN MINIMUM.
- SIZE OF TRANSFORMER FOR SIGNALS SHALL BE 5 KVA. SIZE OF TRANSFORMER FOR 120 V INTERSECTION SHALL BE 2 KVA.
- WHEN CHANGING VOLTAGE ON A RETROFIT PROJECT WHERE A NEW SERVICE ENCLOSURE WITH A STEP-DOWN TRANSFORMER IS REQUIRED, THE NEW SERVICE ENCLOSURE THE NEW SERVICE ENCLOSURE SHALL BE PLACED BETWEEN THE SERVICE POINT AND THE OLD SERVICE ENCLOSURE LOCATION WITHIN THE CITY R/W. VOLTAGE OUTPUT FROM THE NEW SERVICE ENCLOSURE MAY BE CONNECTED INTO THE EXISTING CONDUIT SYSTEM.
- THE WIRING SCHEMATIC DIAGRAM AS SHOWN IS FOR A 2-WIRE STREET LIGHTING SYSTEM. IF THE SERVICE ENCLOSURE WILL BE USED FOR A 3-WIRE STREET LIGHTING SYSTEM, THEN THE LIGHTING BREAKERS SHALL CONSIST OF 2-POLE BREAKERS WITH INTERNAL COMMON TRIP, EACH POLE WITH INDIVIDUAL ON-OFF CONTROL AND HANDLE TIE FOR COMMON OPERATION. FOR EACH 2-POLE BREAKER, THE CIRCUIT LOAD SHALL BE EQUALLY DIVIDED ACROSS THE LIGHTING MAIN.
- SEE STANDARD SPECIFICATIONS FOR ADDITIONAL DETAILS.
- DUAL METERS SHALL BE PROVIDED AND SHALL CONFORM TO CALTRANS STANDARD DRAWING ES-2F.

* BREAKER SIZE DETERMINED BY LOAD REQUIREMENTS (30 AMP MINIMUM)
 ** PROVIDE A 15 AMP, 1P CIRCUIT BREAKER FOR IISNS. MODIFY WIRINGS TO USE LIGHTING CONTACTOR FOR IISNS.

DATE: 09/22/2007		NOT TO SCALE	
REVISION	BY	APPROVED	DATE

CITY OF ELK GROVE - PUBLIC WORKS

**METERED SERVICE PEDESTAL (Can)
WITH STEP-DOWN TRANSFORMER
(277/480V TO 120/240V)**

APPROVED BY:

 CITY ENGINEER 10/24/2018
 DATE

DRAWING NUMBER
SL - 9

